

This file is available for free download at <http://www.iluvmyrx7.com>

This file was not scanned to deprive Mazda of any money - it was scanned due to the rareness of the original manuals and the overwhelming need of the RX-7 owner to have this information so that they can accurately troubleshoot problems. Perhaps if Mazda's dealerships could support the Rotary Engine it wouldn't be so necessary for the owners to do so.



Many thanks to Lenny Terris for scanning this.

Before beginning any service procedure, refer to the 1994 RX-7 Body Electrical Troubleshooting Manual; see section S for air bag system service warnings and section J1 for audio antitheft system alarm conditions.

N

STEERING SYSTEM

INDEX	N - 2
OUTLINE	N - 3
SPECIFICATIONS	N - 3
ENGINE SPEED SENSING POWER	
STEERING	N - 3
PREPARATION	N - 3
TROUBLESHOOTING GUIDE	N - 5
AIR BLEEDING	N - 6
POWER STEERING FLUID	N - 6
BOOT	N - 9
STEERING WHEEL AND COLUMN	N - 11
STEERING GEAR AND LINKAGE	N - 16
POWER STEERING OIL PUMP	N - 28
DRIVE BELT	N - 31

N

INDEX

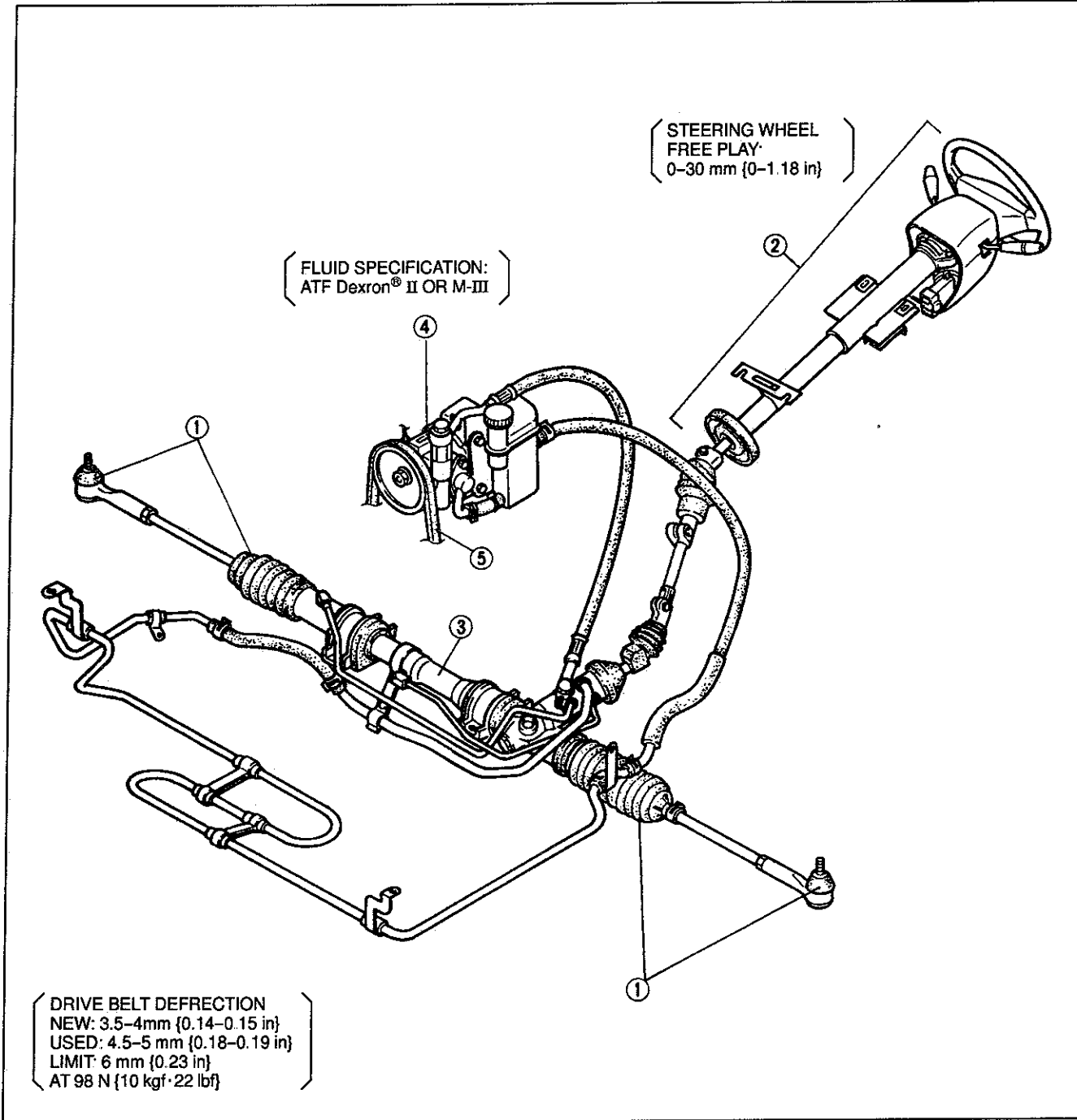

1. Boot	
Replacement	page N- 9
2. Steering wheel and column	
On-vehicle inspection	page N-11
Removal / Inspection /	
Installation	page N-12
Disassembly / Inspection /	
Assembly	page N-14
3. Steering gear and linkage	
Removal / Installation	page N-16
Disassembly / Inspection	page N-18
Assembly	page N-23
Air bleeding	page N- 6

4. Power steering oil pump	
Removal / Installation	page N-28
Disassembly / Inspection /	
Assembly	page N-29
Air bleeding	page N- 6
Power steering fluid	page N- 6
5. Drive belt	
Inspection	page N-31
Adjustment	page N-31
Replacement	page N-31





OUTLINE

SPECIFICATIONS

Item		Specifications
Steering wheel	Outer diameter mm (in)	380 {15.0}
	Lock-to-lock turns	2.9
Steering shaft	Shaft	Collapsible
Steering gear	Power assist	Engine speed sensing
	Gear	Rack-and-pinion
	Gear ratio	∞ (infinite)
	Back stroke mm (in)	160 {6.30}
	Power steering fluid	ATF Dexron® II or M-III
Fluid capacity L {US qt, Imp qt}	0.96 {1.01, 0.84}	

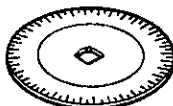
ENGINE SPEED SENSING POWER STEERING

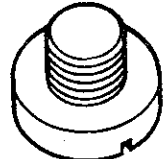
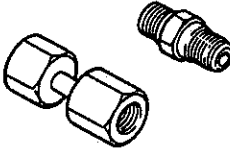
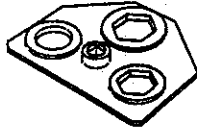

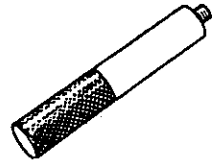
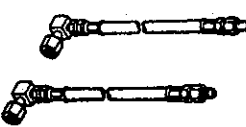
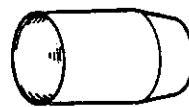







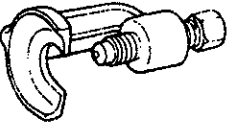
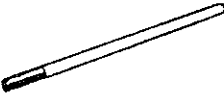

PREPARATION
SST

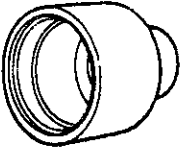
49 1232 670A Gauge set, power steering 	For inspection of power steering fluid pressure	49 D032 316 Protractor 	For installation of adjusting cover
49 1232 673 Body, valve (Part of 49 1232 670A) 	For inspection of power steering fluid pressure	49 F032 317 Remover, oil seal 	For removal of oil seal and backup washer
49 H032 322 Adapter, power steering gauge 	For inspection of power steering fluid pressure	49 F032 313 Wrench 	For removal of locknut
49 1232 672 Gauge (Part of 49 1232 670A) 	For inspection of power steering fluid pressure	49 F032 305 Handle 	For removal of needle bearing
49 H002 671 Adapter, power steering gauge 	For inspection of power steering fluid pressure	49 F032 310 Protector 	For installation of oil seal

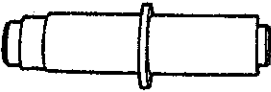
N

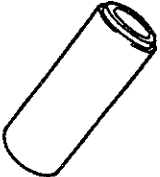
N

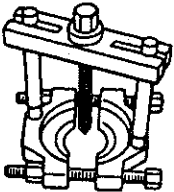
ENGINE SPEED SENSING POWER STEERING

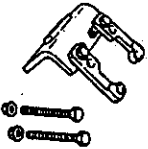
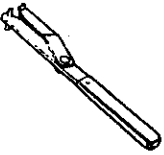
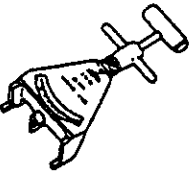
<p>49 0118 850C Puller, ball joint</p> 	<p>For removal of tie rod end ball joint</p>	<p>49 F032 303 Handle</p> 	<p>For installation of oil seal and backup washer</p>
<p>49 G032 3A1 Set, joint hose</p> 	<p>For hermetic inspection of cylinder</p>	<p>49 G032 317 Hose (Part of 49 G032 3A1)</p> 	<p>For hermetic inspection of cylinder</p>
<p>49 G032 319 Adapter (Part of 49 G032 3A1)</p> 	<p>For hermetic inspection of cylinder</p>	<p>49 H032 301 Wrench</p> 	<p>For removal of tie rod</p>
<p>49 1243 785 Installer, boot</p> 	<p>For installation of outer ball joint</p>	<p>49 H032 328 Former, seal ring</p> 	<p>For formation of seal ring</p>
<p>49 F032 318 Installer, oil seal and bearing</p> 	<p>For installation of oil seal and bearing</p>	<p>49 F032 304 Body</p> 	<p>For installation of oil seal</p>
<p>49 F032 319 Installer</p> 	<p>For installation of oil seal</p>	<p>49 0180 510B Attachment, preload</p> 	<p>For measurement of pinion preload</p>
<p>49 0710 520 Puller, bearing</p> 	<p>For removal of bearing</p>	<p>49 F032 306A Body</p> 	<p>For removal of needle bearing</p>
<p>49 F032 301 Hanger, power steering pump</p> 	<p>For disassembly / assembly of power steering oil pump</p>	<p>49 W023 585A Adjust wrench</p> 	<p>For removal / installation of oil pump pulley</p>
<p>49 9200 020 V-ribbed belt tension gauge</p> 	<p>For measurement of drive belt tension</p>		

TROUBLESHOOTING GUIDE

Problem	Possible cause	Action	Page/section
Steering feels heavy	Poor lubrication, foreign material, or abnormal wear of steering ball joint Stuck or damaged lower arm ball joints Improper steering pinion preload Damaged steering gear Damaged steering shaft joint Improperly adjusted wheel alignment Incorrect tire pressure Loose or damaged oil pump drive belt Low fluid level or air in fluid Leakage of fluid Insufficient oil pump pressure	lubricate or replace Replace Repair or replace Repair or replace Replace Adjust Adjust Adjust or replace Add fluid or bleed air Repair or replace Replace	N- 9 Section R N-26 N-16, 18 N-12 Section R Section Q N-31 N- 6 — N-28
Steering wheel pulls to one side	Incorrect tire pressure Unevenly worn tires Weak front coil spring Worn or damaged stabilizer and/or suspension bushing Dragging brake Loose lower arm Improperly adjusted wheel alignment	Adjust Replace Replace Replace Replace Repair or adjust Tighten or replace Adjust	Section Q Section Q Section R Section R Section R Section P Section R Section R
General instability while driving	Incorrect tire pressure Damaged or unbalanced wheel Worn or damaged steering joint Improper steering pinion preload Weak front coil spring Worn or damaged stabilizer and/or upper or lower arm bushing Damaged shock absorber Improperly adjusted wheel alignment	Adjust Adjust or replace Replace Repair or replace Replace Replace Replace Adjust	Section Q Section Q N-12 N-26 Section R Section R Section R Section R
Shake (steering wheel vibrates up/down)	Excessive tire and/or wheel runout Loose lug nuts Unbalanced wheel Cracked or worn engine mount rubber Cracked or worn transmission mount rubber	Replace Tighten Adjust or replace Replace Replace	Section Q Section Q Section Q Section B Section K
Shimmy (steering wheel vibrates circumferentially)	Cracked or worn steering gear mount rubber Loose steering gear mounting bolts Stuck or damaged steering ball joint Excessive tire and/or wheel runout Loose lug nuts Unbalanced wheel Incorrect tire pressure Unevenly worn tires Damaged shock absorber Loose shock absorber mounting bolts Stuck or damaged lower arm ball joint Cracked or worn suspension bushings Damaged or worn front wheel bearing Improperly adjusted front wheel alignment	Replace Tighten Replace Replace Replace Tighten Adjust or replace Adjust Replace Replace Replace Tighten Replace Replace Replace Adjust	N-18 N-16 N- 9, 18 Section Q Section Q Section Q Section Q Section R Section R Section R Section R Section R Section R Section M Section R
Excessive steering wheel play	Worn steering gear Worn or damaged steering joints Worn or damaged lower arm bushing Loose steering gear mounting bolts Worn linkage or tie rod ball joint	Repair or replace Replace Replace Tighten Replace	N-16, 18 N-12 Section R N-16 N-18
Poor steering wheel return	Incorrect tire pressure Stuck or damaged steering joints Improperly adjusted front wheel alignment Improper steering pinion preload Ball joint not operating smoothly Obstruction near steering column	Adjust Replace Adjust Repair or replace Replace Repair	Section Q N-12 Section R N-26 N-16, 18 N-12

N

TROUBLESHOOTING GUIDE (Cont'd)

Problem	Possible cause	Action	Page/section
Abnormal noise from steering system	Loose oil pump	Tighten	N-28
	Loose steering gear	Tighten	N-16
	Loose oil pump bracket	Tighten	N-28
	Loose or too tight drive belt	Adjust	N-31
	Air in system	Bleed air	N- 6
	Damaged steering gear	Repair or replace	N-16, 18
	Damaged oil pump	Repair or replace	N-28, 29
	Obstruction near steering column	Repair or replace	N-12
	Loose steering linkage	Tighten or replace	N-16
	Worn steering joints	Replace	N-12

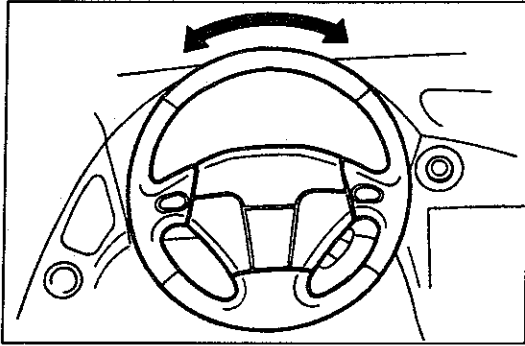

AIR BLEEDING

1. Check the fluid level. (Refer to below.)
2. Jack up the front of the vehicle and support it on safety stands.
3. Turn the steering wheel fully to the left and right several times with the engine not running.
4. Recheck the fluid level. If it has dropped, add fluid.
5. Repeat Steps 3 and 4 until the fluid level stabilizes.
6. Lower the vehicle.
7. Start the engine and let it idle.
8. Turn the steering wheel fully to the left and right several times.
9. Verify that fluid is not foamy and that the fluid level has not dropped.
10. Add fluid if necessary and repeat Steps 6 and 7.

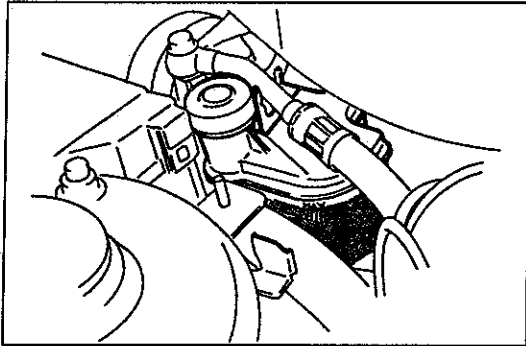

POWER STEERING FLUID

Inspection

Fluid level

Check the power steering fluid level. Add specified power steering fluid to MAX if necessary.

Fluid specification: ATF Dexron® II or M-III

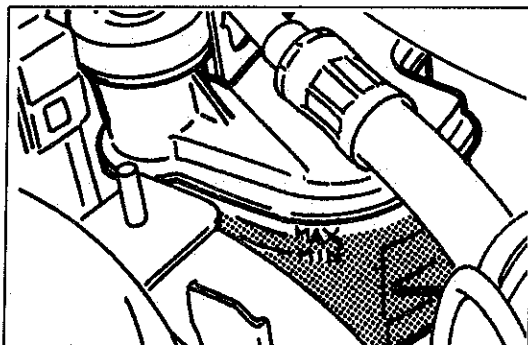

Fluid leakage

Caution

- Never hold the steering wheel to the extreme left or right for more than five seconds with the engine running. This could damage the power steering pump.

Start the engine and let it idle. Turn the steering wheel fully left and fully right to apply fluid pressure. Inspect the points shown in the figure for fluid leakage.

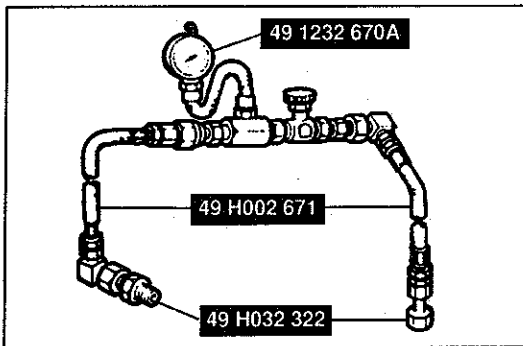
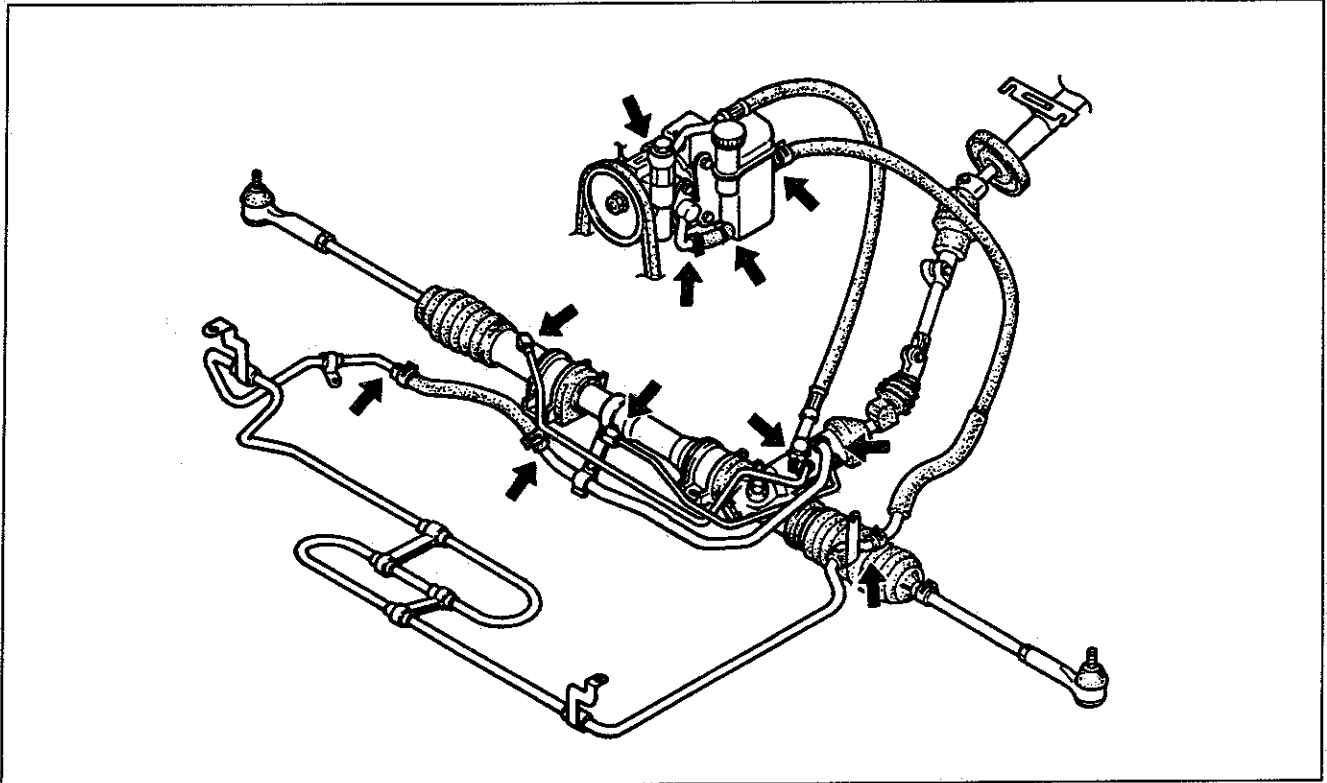

Fluid pressure

1. Assemble the SST as shown in the figure.

Tightening torque:

40–49 N·m {4.0–5.0 kgf·m, 29–36 ft·lbf}

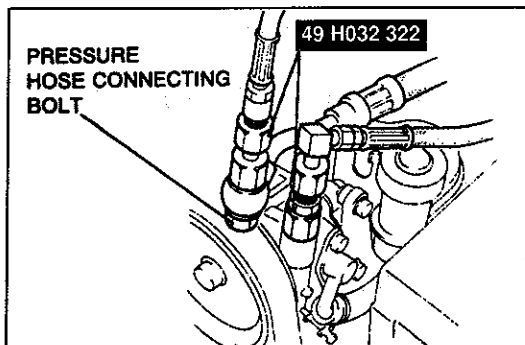

2. Disconnect the pressure pipe from the oil pump, and connect the SST.
3. Bleed the air from the system. (Refer to page N-6.)

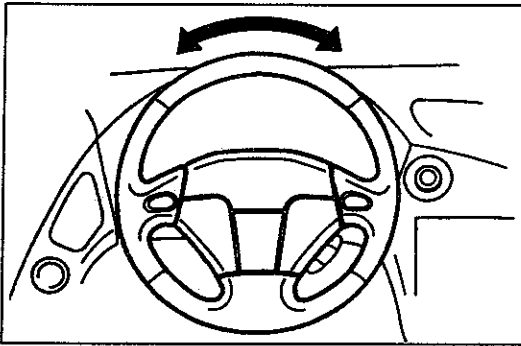
**Caution**

- Never hold the steering wheel to the extreme left or right for more than 15 seconds with the engine running. This could damage the power steering pump.

4. Open the gauge valve fully. Start the engine and turn the steering wheel fully left and right to raise the fluid temperature to 50–60°C {122–144°F}.

Caution

- Do not let the valve stay closed for more than 15 seconds. The increase in fluid temperature will damage the oil pump.

5. Close the gauge valve completely. Increase the engine speed to 1,000–1,500 rpm and measure the fluid pressure generated by the oil pump. If the pressure is not within specification, repair or replace the oil pump assembly. (Refer to page N-28.)

Oil pump fluid pressure:

7,620–8,350 kPa {77.7–85.2 kgf/cm², 1,110–1,210 psi}

6. Open the gauge valve fully and increase the engine speed to 1,000–1,500 rpm.

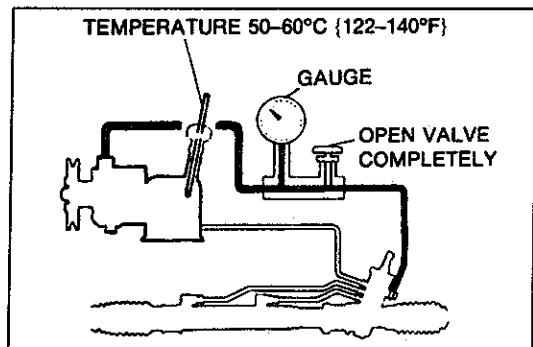
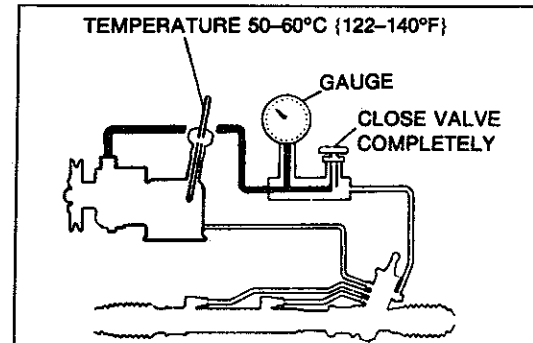

7. Turn the steering wheel fully to the left and right and measure the fluid pressure generated at the gear housing. If the pressure is not within specification, repair or replace the steering gear assembly.

Gear housing fluid pressure:

7,620–8,350 kPa {77.7–85.2 kgf/cm², 1,110–1,210 psi}

8. Remove the gauge set. Install and tighten the pressure pipe to the specified torque.

Tightening torque:

24–35 N·m {2.4–3.6 kgf·m, 18–26 ft·lbf}

9. Bleed the air from the system. (Refer to page N-6.)

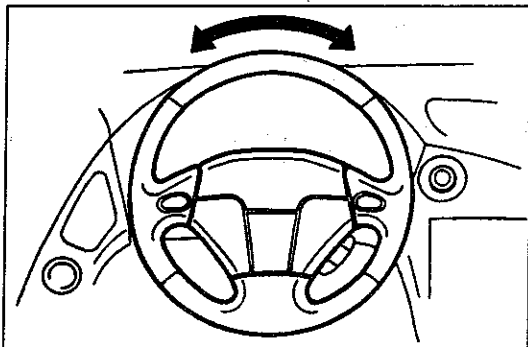

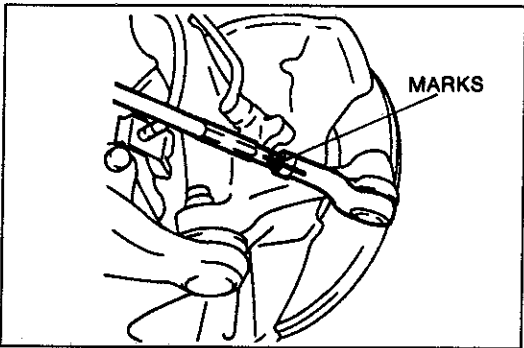
**Removal note****Locknut**

Before loosening the tie rod end locknut, make mark for reference when tightening.

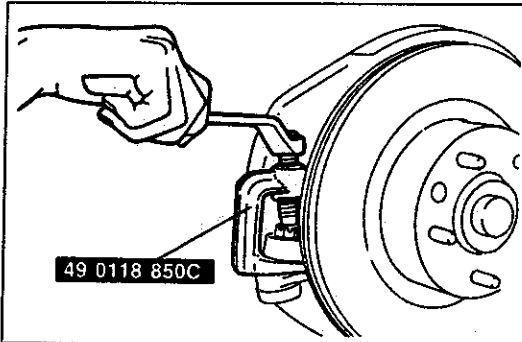
**Tie rod end ball joint**

1. Loosen the tie rod end ball joint nut until it is about flush with the end of the stud.
2. With the nut protecting the stud, separate the tie rod end from the steering knuckle by using the SST.

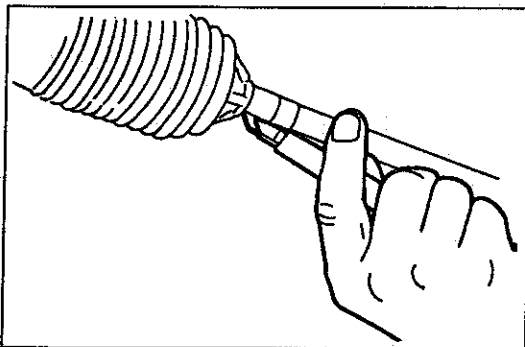
**Steering gear boot**

If the steering gear boot is difficult to remove, use a razor knife to cut open the small diameter end.

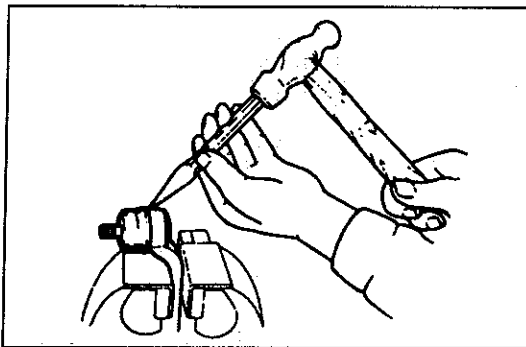
**Tie rod end boot**

1. Secure the tie rod end in a vise.
2. Place a chisel against the boot and hold it at an angle as shown.
3. Remove the boot by tapping it with a hammer.

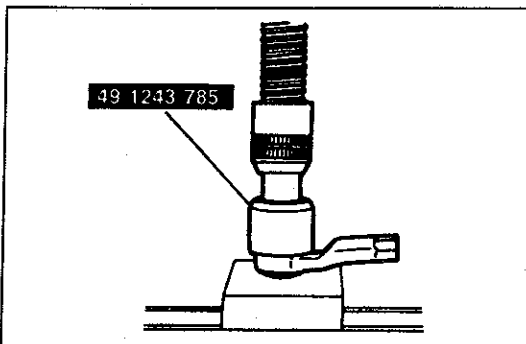
**Installation note****Tie rod end boot**

1. Wipe away the grease on the ball joint.
2. Put a small amount of grease (lithium base) into the new boot and set it onto the tie rod end.
3. Press the boot onto the tie rod end by using the SST and a press.
4. Wipe away any excess grease.

Steering gear boot

Verify that the boot is not twisted.

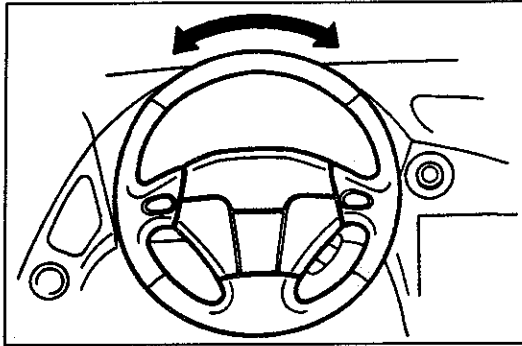
**STEERING WHEEL AND COLUMN****On-vehicle Inspection****Steering wheel play**

1. With the wheels in the straight-ahead position, gently turn the steering wheel to the left and right and verify that the play is within specification.

Play: 0–30 mm {0–1.18 in}

2. If the play exceeds specification, check the steering joints for wear and check the steering gear for excessive backlash. Correct as necessary.

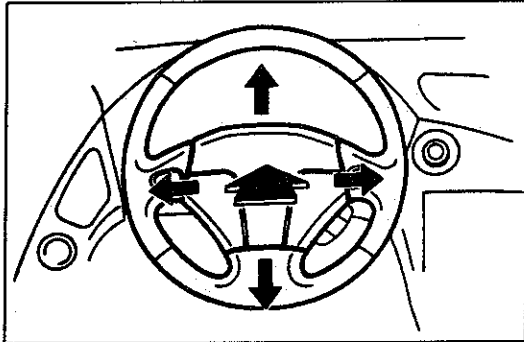
**Looseness or play of steering wheel**

1. Move the steering wheel in the directions of the arrows to check for column bearing wear, steering shaft joint play, steering wheel looseness, and column looseness.
2. If looseness is noted, inspect for the cause and repair as necessary.

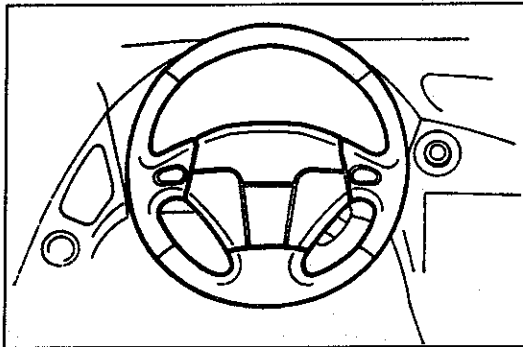
**Steering wheel effort**

1. With the vehicle on a hard, level surface, put the wheels in the straight-ahead position.
2. Start the engine and warm the power steering fluid to 50–60°C {122–140°F}.

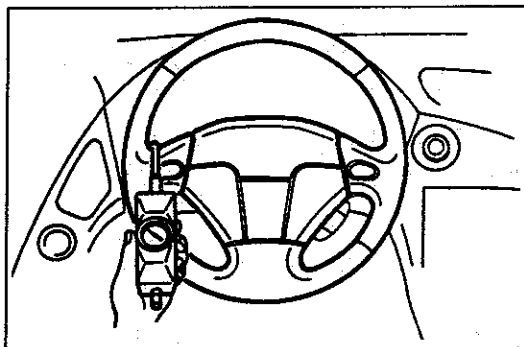

3. With the engine running at idle, attach a pull scale to the outermost point of the steering wheel spoke. Then, starting with the wheels in the straight-ahead position, measure the effort required to turn the steering wheel to the left and to the right.

Steering wheel effort:

30–38 N {3.0–3.9 kgf, 6.6–8.5 lbf}

[during one turn of the steering wheel]

4. If not within specification, check the following: fluid level, air in system, fluid leakage in piping or connections, function of oil pump and gear box, and tire pressures.

Removal / Inspection / Installation

1. Disconnect the negative battery cable.
2. Remove in the order shown in the figure, referring to **Removal Note**.
3. Inspect all parts and repair or replace as necessary.
4. Install in the reverse order of removal, referring to **Installation Note**.

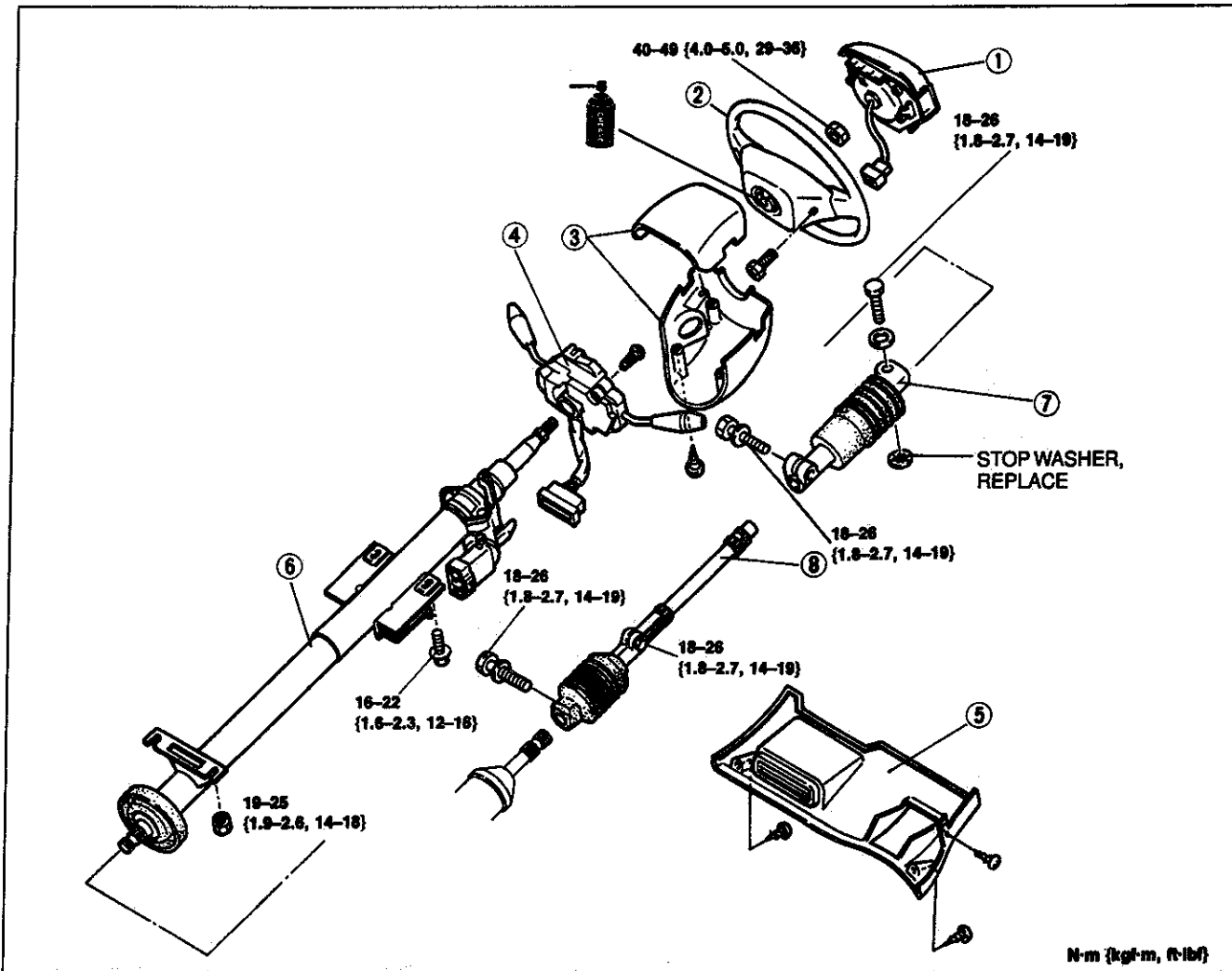

- | | |
|---|---|
| <ol style="list-style-type: none"> 1. Air bag module
Service 1994 RX-7 Body Electrical Troubleshooting Manual 2. Steering wheel
Removal Note page N-13
Installation Note page N-13 3. Column cover 4. Combination switch
Service 1994 RX-7 Body Electrical Troubleshooting Manual 5. Lower panel | <ol style="list-style-type: none"> 6. Steering shaft assembly
Installation Note page N-13
Disassembly / Inspection / Assembly page N-14
Inspect dust cover for damage 7. Steering joint
Installation Note page N-13
Inspect for damage and poor operation
Inspect boot for cracking and tearing 8. Intermediate shaft
Installation Note page N-13
Inspect for damage and bending
Inspect boot for cracking and tearing |
|---|---|

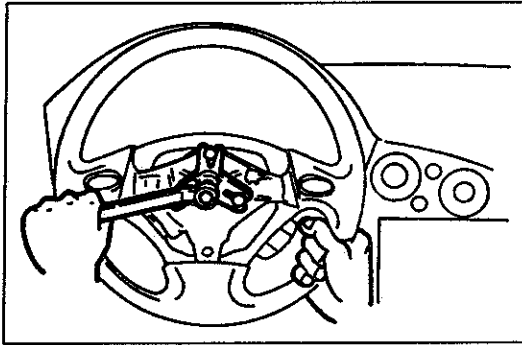

Removal note
Steering wheel

Caution

- Do not try to remove the steering wheel by hitting the shaft with a hammer. The column will collapse.

Remove the steering wheel by using a suitable puller.

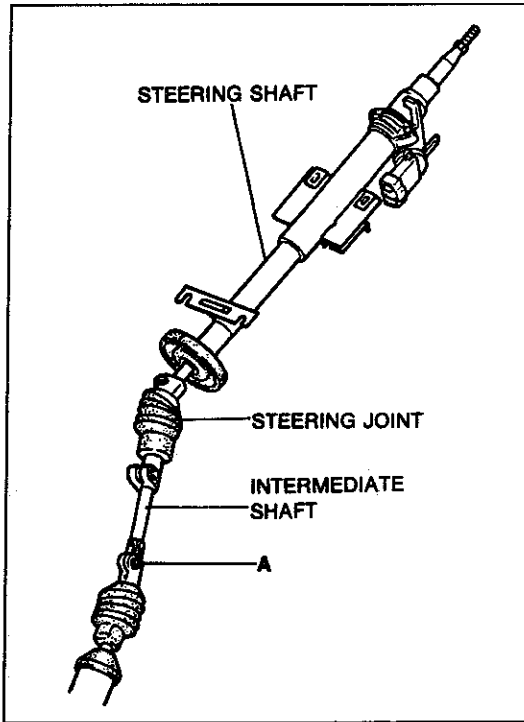

Intermediate shaft

Note

- Bolt A can be loosened but not removed from the intermediate shaft.

Installation note

Steering shaft, steering joint, and intermediate shaft

Assemble the steering shaft, steering joint, and intermediate shaft, then tighten the bolts. Tighten bolt A last.

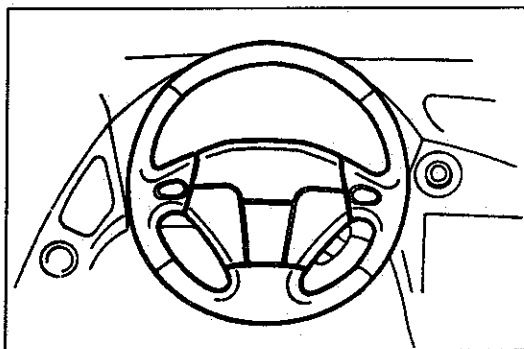

Steering wheel

Install the steering wheel with the wheels in the straight-ahead position.

Disassembly / Inspection / Assembly

1. Disassemble in the order shown in the figure, referring to **Disassembly Note**.
2. Inspect all parts and repair or replace as necessary.
3. Assembly in the reverse order of disassembly, referring to **Assembly Note**.

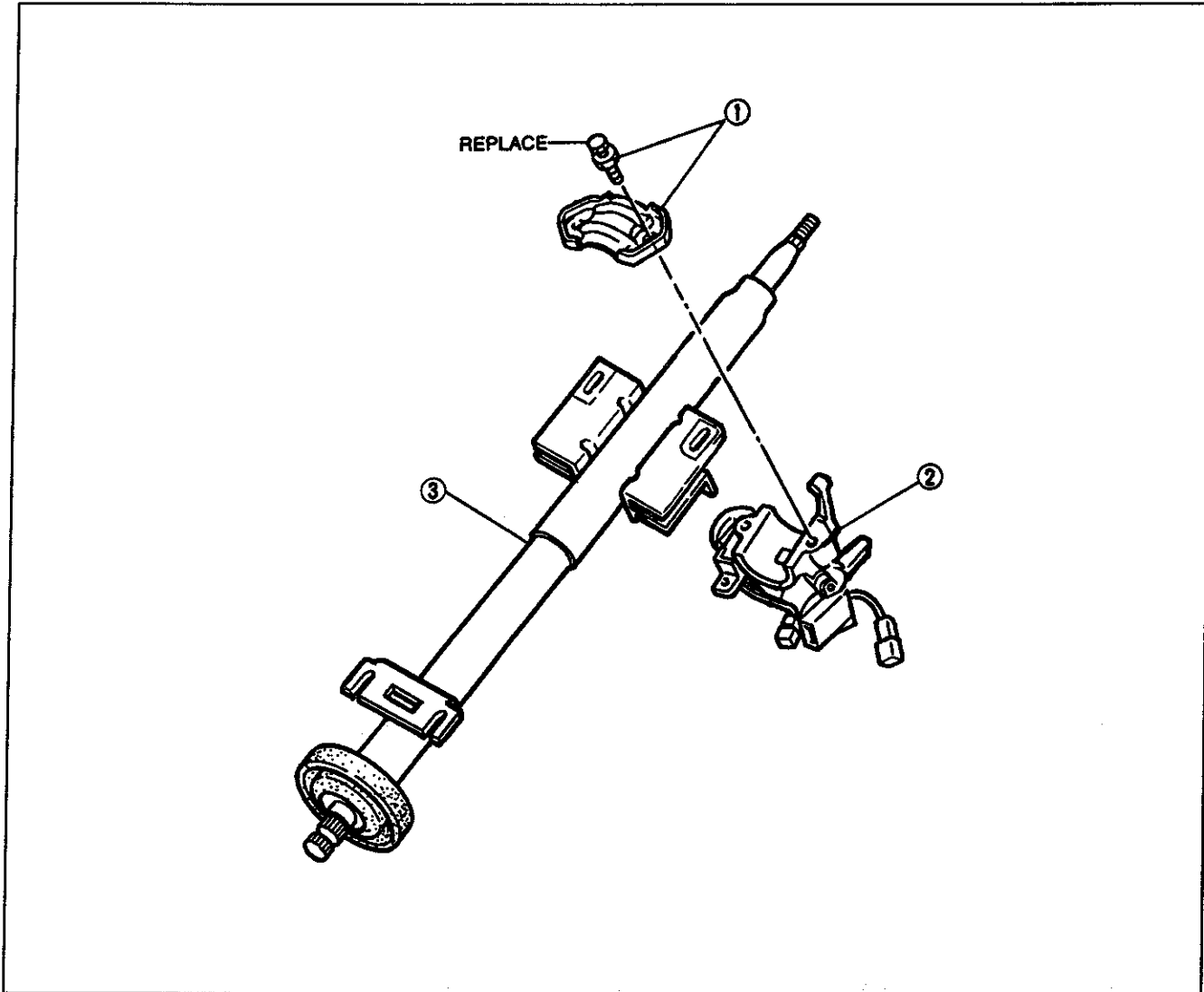

- | | |
|--|---|
| <ol style="list-style-type: none"> 1. Steering lock mounting bolts and bracket
Disassembly Note below
Assembly Note page N-15 2. Steering lock assembly
Inspection page N-15 | <ol style="list-style-type: none"> 3. Steering shaft assembly
Inspection page N-15 |
|--|---|

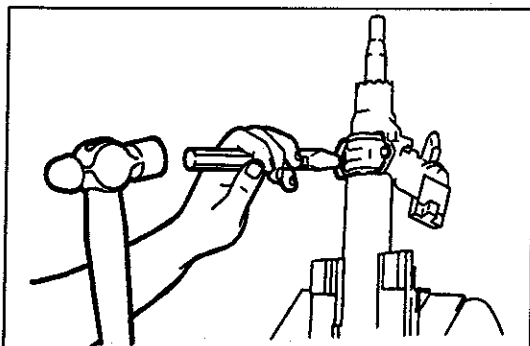

Disassembly note

Steering lock mounting bolts and bracket

1. Secure the steering shaft in a vise.
2. Use a chisel to make a groove in the heads of the steering lock mounting bolts.
3. Remove the bolts by using a screwdriver.
4. Remove the steering lock assembly.

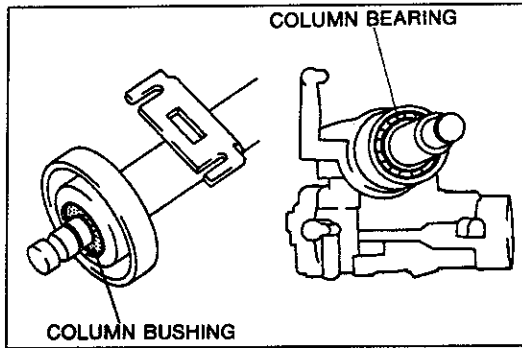

Inspection

Steering shaft assembly

Check for the following and replace the steering shaft assembly if necessary.

1. Column bearing for damage
2. Column bushing for damage

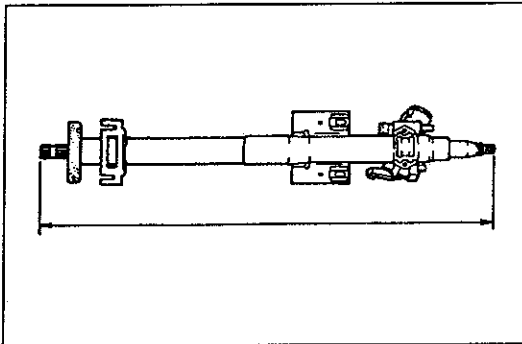

3. Steering shaft length

Length: 779.5–781.5 mm {30.69–30.76 in}

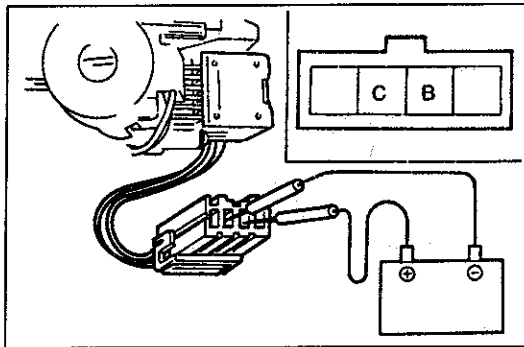

Steering lock assembly

1. Insert the ignition key in the key cylinder. Apply battery positive voltage between terminals B and C.
2. Verify that the solenoid operates.
3. If not as specified replace the key interlock solenoid. (Refer to section K).

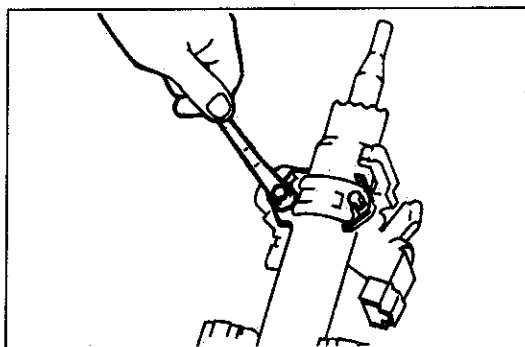

Assembly note

Steering lock mounting bolts and bracket

1. Install the steering lock assembly on the jacket.
2. Verify that the lock operates correctly.
3. Install new steering lock mounting bolts.
4. Tighten each bolt until its head breaks off.

STEERING GEAR AND LINKAGE

Removal / Installation

1. Jack up the front of the vehicle and support it on safety stands.
2. Remove the wheels and tires and the undercover.
3. Remove in the order shown in the figure, referring to **Removal Note**.
4. Install in the reverse order of removal, referring to **Installation Note**.
5. Install the wheels and tires.

Tightening torque: 89–117 N·m{9.0–12.0 kgf·m, 66–86 ft·lbf}

6. Install the undercover.

7. After installation:

- (1) Check for fluid leakage. (Refer to page N-7.)
- (2) Bleed air from the system. (Refer to page N-6.)
- (3) Check, and if necessary adjust, the toe-in and maximum steering angle.

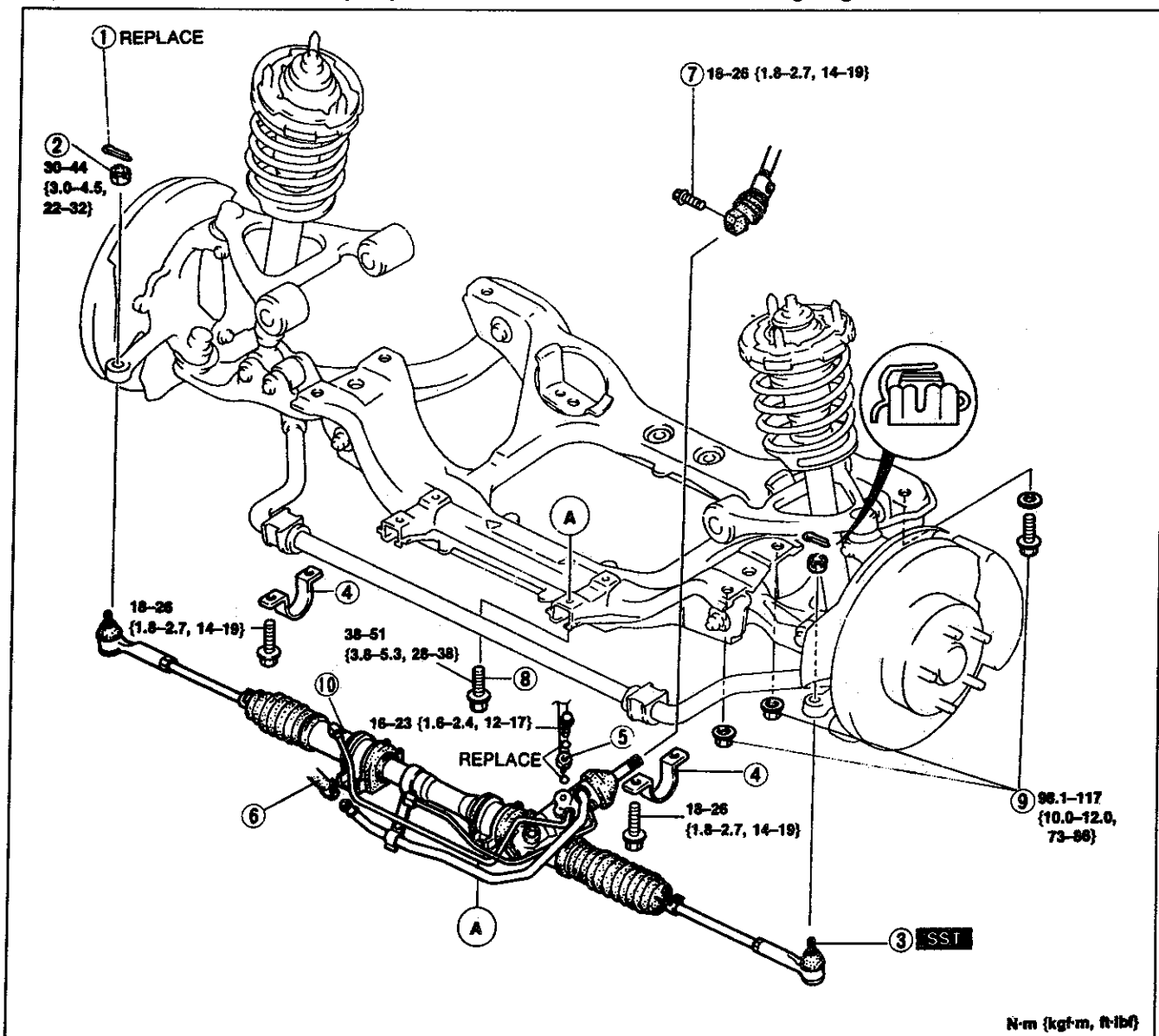

- 1. Cotter pin
- 2. Nut
- 3. Tie rod end ball joint
Removal Note page N-10
- 4. Stabilizer bracket
- 5. Pressure hose
Installation Note Below
- 6. Return hose

- 7. Bolt(steering joint / pinion shaft)
- 8. Mounting bracket bolts
Installation Note Below
- 9. Crossmember nuts and bolts
Removal Note Below
- 10. Steering gear and linkage
Removal Note Below
Disassembly / Inspection page N-18
Assembly page N-23

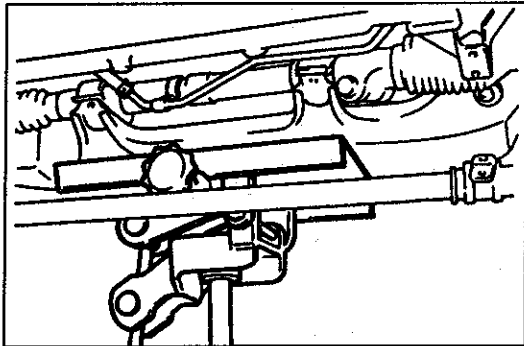

Removal note

Crossmember nuts and bolts, steering gear and linkage

- 1. Support the crossmember with a jack, and remove the crossmember nuts, and bolts.
- 2. Slowly lower the crossmember and remove the steering gear and linkage.

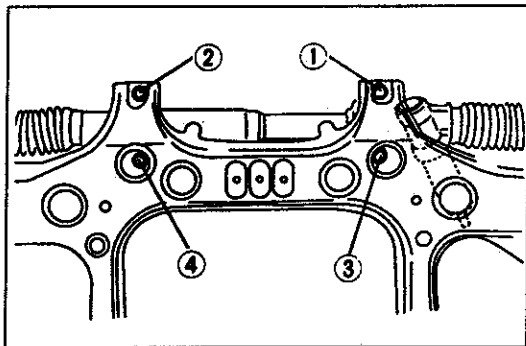

Installation note

Mounting bracket bolts

- 1. Loosely tighten the bolts 3 and 4.
- 2. Tighten all of the mounting bracket bolts to the specified torque in the order shown.

Tightening torque:

38-51 N·m{3.8-5.3 kgf·m,27-38 ft·lbf}

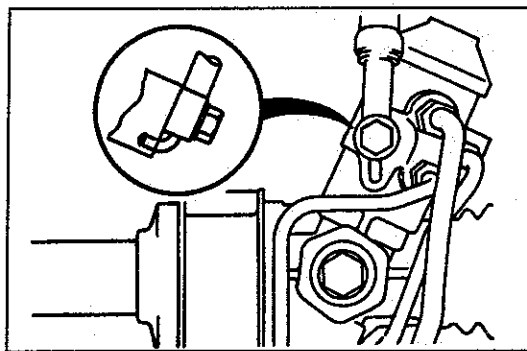

Pressure hose

Before assembly, align the pin with the positioning hole.

Disassembly / Inspection

1. Disassemble in the order shown in the figure, referring to **Disassembly Note**.
2. Inspect all parts and repair or replace as necessary.

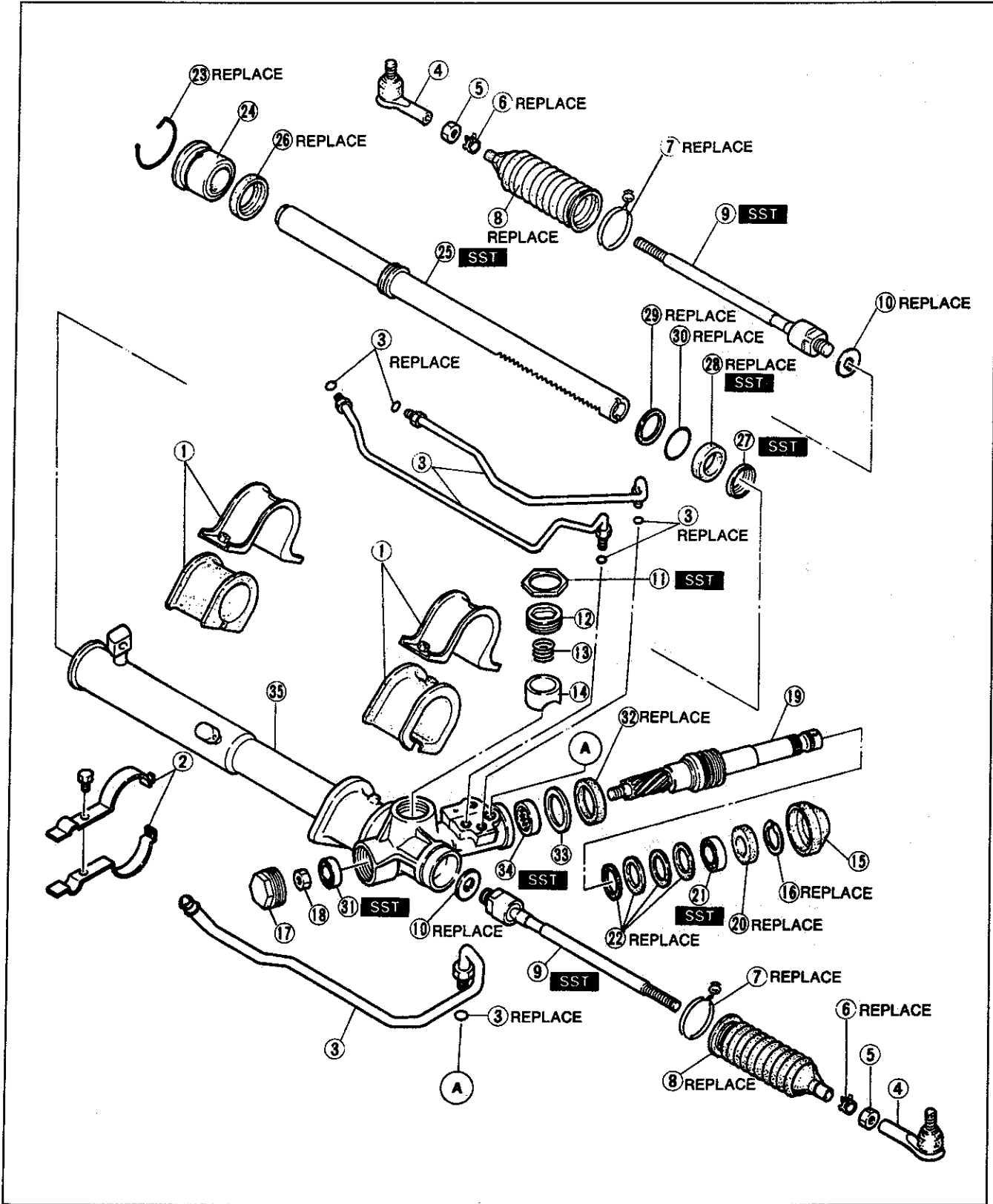

- 1. Mounting bracket and rubber
- 2. Pipe clamp
- 3. Oil pipe and O-ring
Inspect for clogging and damage
- 4. Tie rod end
Inspection page N-22
Disassembly Note Below
- 5. Locknut (tie rod end)
- 6. Boot clamp
- 7. Boot wire
- 8. Boot
Disassembly Note Below
- 9. Tie rod
Inspection page N-22
Disassembly Note page N-20
- 10. Washer (tie rod)
- 11. Locknut (adjusting cover)
Disassembly Note page N-20
- 12. Adjusting cover
- 13. Yoke spring
Inspect for damage
- 14. Support yoke
Inspect for damage
- 15. Dust cover
- 16. Snap ring
- 17. Housing cover
- 18. Locknut (pinion shaft)
- 19. Pinion shaft assembly
Inspect teeth for wear and damage
Inspect valve for clogging,
damage and wear
Disassembly Note page N-20
- 20. Oil seal
- 21. Upper bearing
Inspect for wear and damage
Disassembly Note page N-20
- 22. Seal ring
Disassembly Note page N-20
- 23. Clip
Disassembly Note page N-21
- 24. Rack stop
Disassembly Note page N-21
- 25. Rack
Disassembly Note page N-21
Inspection page N-22
- 26. Oil seal
Disassembly Note page N-21
- 27. Backup washer
Disassembly Note page N-21
- 28. Oil seal
Disassembly Note page N-21
- 29. Seal ring
Disassembly Note page N-21
- 30. O-ring
Disassembly Note page N-21
- 31. Lower bearing
Disassembly Note page N-21
Inspect for wear and damage
- 32. Oil seal
Disassembly Note page N-21
- 33. Washer
- 34. Needle bearing
Disassembly Note page N-22
Inspect for wear and damage
- 35. Gear housing
Inspect for damage and cracks

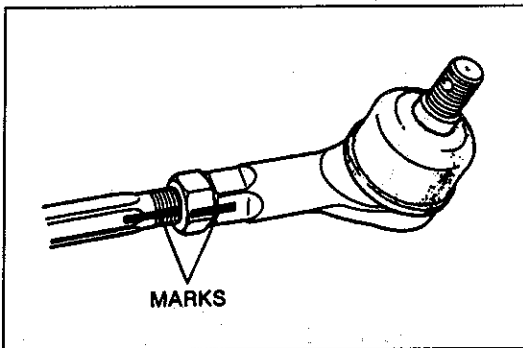

Disassembly note
Tie rod end

Before loosening, mark the tie rod end as shown for reference during installation.

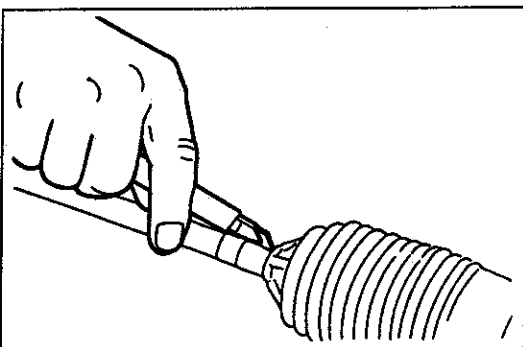

Boot

If the boot is difficult to remove, use a razor knife to cut open the small diameter end.

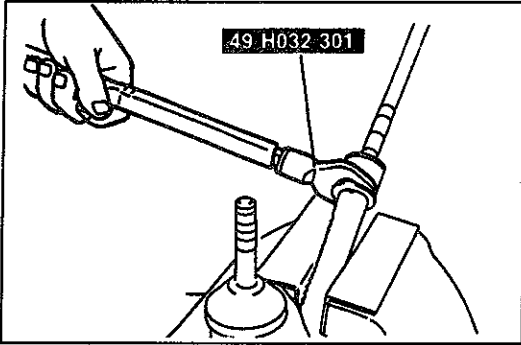

Tie rod

1. Unbend the washer
2. Remove the tie rod by using the SST.

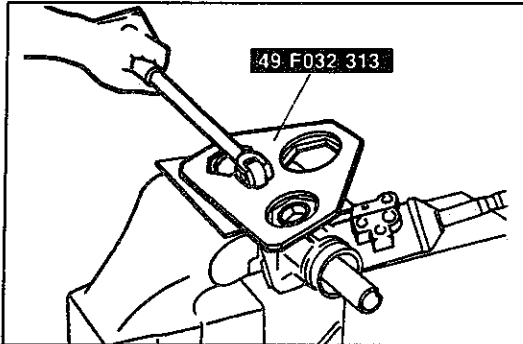

Locknut

Remove the locknut by using the SST.

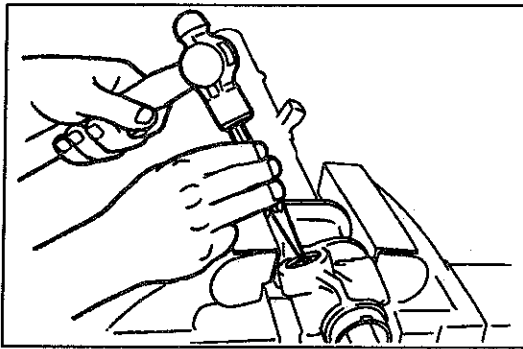

Pinion shaft assembly

Place a punch on the center of the shaft, and tap lightly with a hammer to remove it.

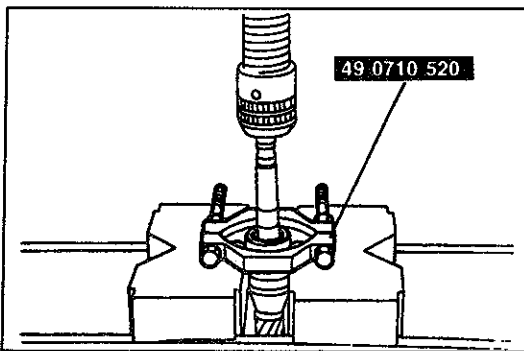

Upper bearing

Note

- The upper bearing does not need to be removed unless you are replacing it.

Remove the upper bearing by using the SST.

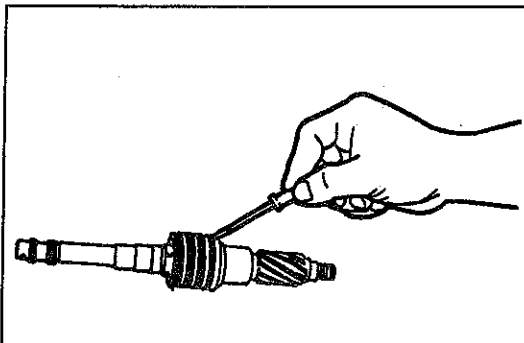

Seal ring

Remove the seal rings by using a small, cloth-wrapped screwdriver.

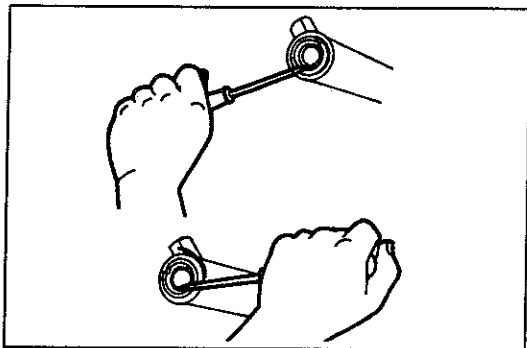

Clip and rack stop

1. Turn the rack stop in the direction that is easiest to turn, until the end of the clip comes out of the hole. Do not force the clip and rack stop when turning.
2. Turn the rack stop the opposite direction and remove the clip.
3. Remove the rack stop.

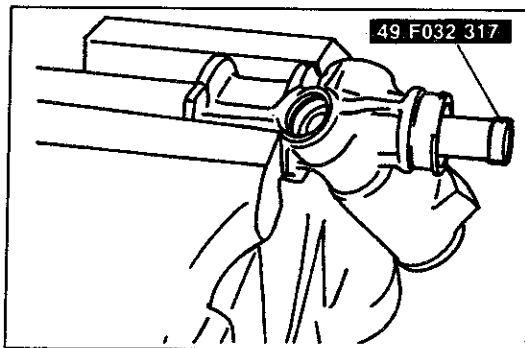

Rack, oil seal and backup washer

1. Set the SST into the end of the rack.
2. Pull out the rack assembly, with the oil seal and backup washer.

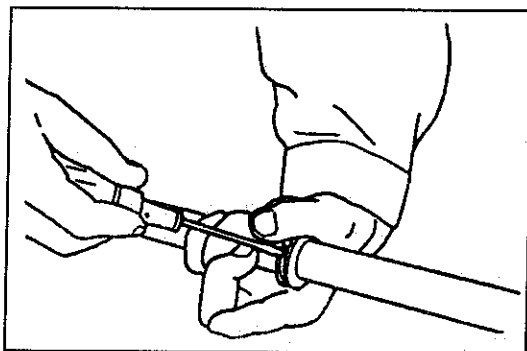

Seal ring and O-ring

1. Remove the seal ring by using a small screwdriver.
2. Remove the O-ring.

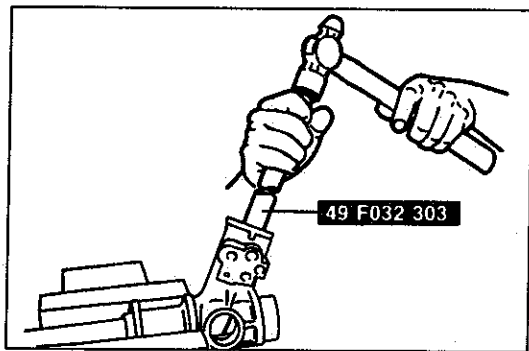

Lower bearing

Drive the lower bearing out of the housing by using the SST.

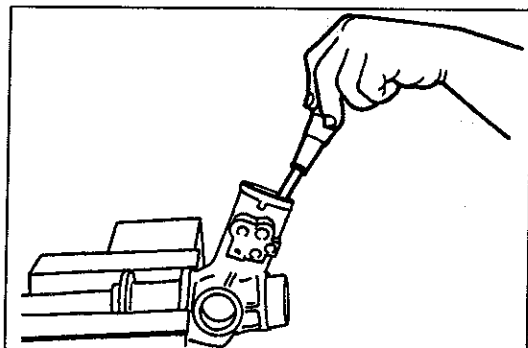

Oil seal

Remove the oil seal, being careful not to scratch the inner surface of the valve housing.

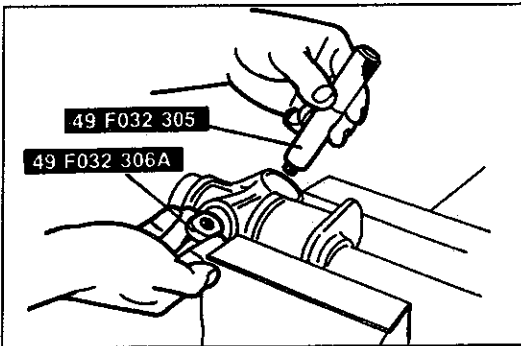
**Needle bearing**

1. Insert the SST (body) through the adjusting cover hole.
2. Set the SST (handle) against the SST of Step 1.

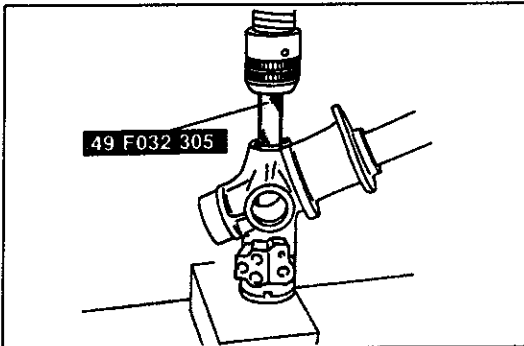

3. Press out the needle bearing by using SST.

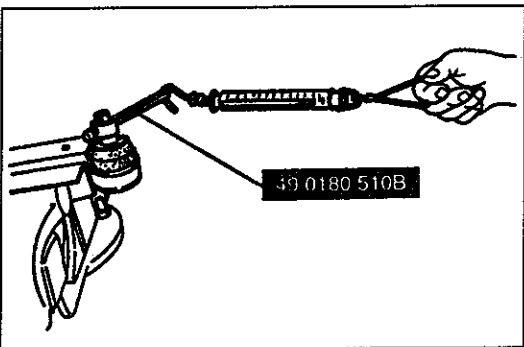
**Inspection****Tie rod end**

1. Inspect the tie rod end for damage and the boot cracks. Replace as necessary.
2. Inspect the ball joint for looseness. Replace the tie rod end if necessary.
3. Shake and rotate the ball joint several times.
4. Measure the rotation torque of the ball joint by using the SST and a pull scale.

Rotation torque:

0.3–2.9 N·m {3–30 kgf·cm, 2.6–26 in·lbf}

Pull scale reading: 3–29 N {0.3–3 kgf, 0.7–6.6 lbf}

5. If not within specification, replace the tie rod end.

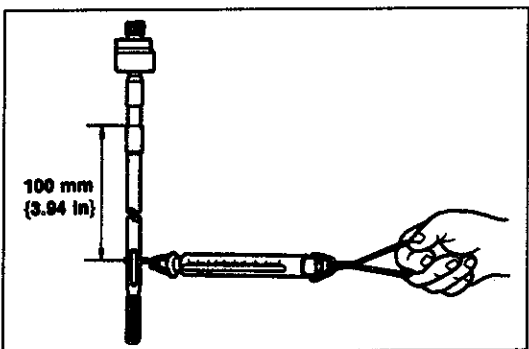
**Tie rod**

1. Inspect the tie rod for bending and damage. Replace it if necessary.
2. Inspect the ball joint for looseness. Replace the tie rod necessary.
3. Swing the tie rod several times.
4. Measure the swinging torque by using a pull scale.

Swinging torque:

0.1–3.4 N·m {1–35 kgf·cm, 0.9–30 in·lbf}

Pull scale reading: 0.7–21 N {0.07–2 kgf, 0.16–4.8 lbf}

5. If not within specification, replace the tie rod.

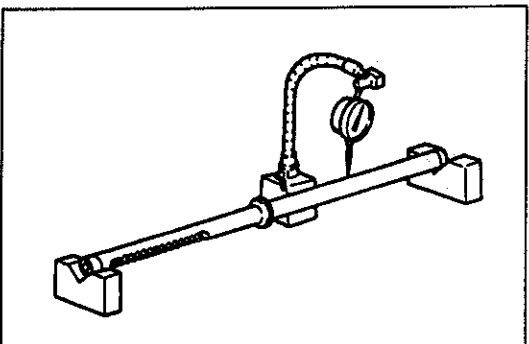
**Rack**

1. Inspect the rack for cracking, damage and tooth wear. Replace it if necessary.
2. Measure runout of the rack.
Runout: 0.4 mm {0.016 in} max.
3. If not within specification, replace the rack.

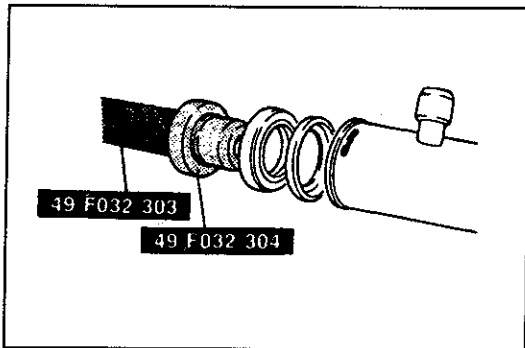
**Assembly****1. Backup washer and oil seal**

- (1) Apply ATF to the new oil seal.
- (2) Install the backup washer and oil seal by using the SST.
- (3) After installing, shake the gear housing and verify that the backup washer does not rattle.
- (4) If it rattles, remove the oil seal and backup washer and reinstall them.

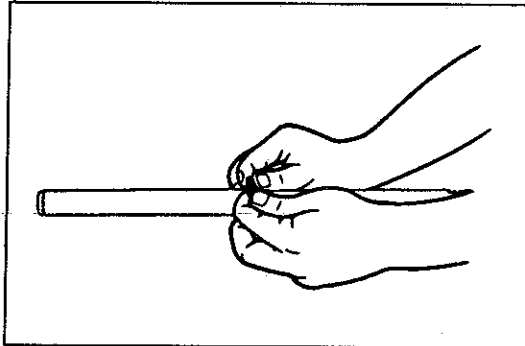
**2. Rack**

- (1) Apply ATF to a new O-ring and seal ring.
- (2) Install the O-ring then seal ring in the piston groove.

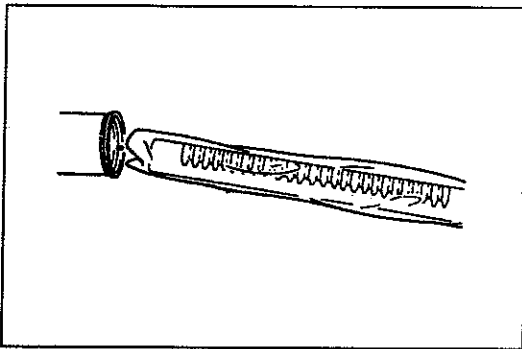

- (3) Apply grease to the friction surface and teeth of the rack.
- (4) Slide the vinyl sleeve supplied in the seal kit over the rack and slide the rack in from the tube side.
- (5) Remove the vinyl sleeve.

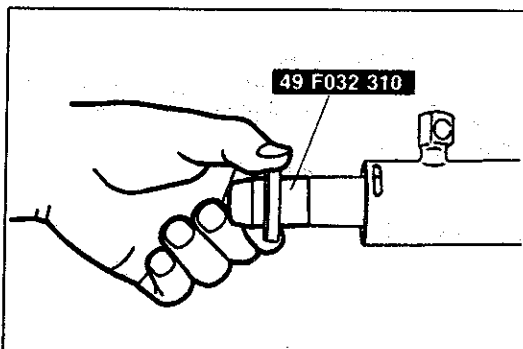
**3. Oil seal**

- (1) Set the SST onto the end of the rack.
- (2) Apply ATF to the new oil seal and slide it onto the end into the rack housing.

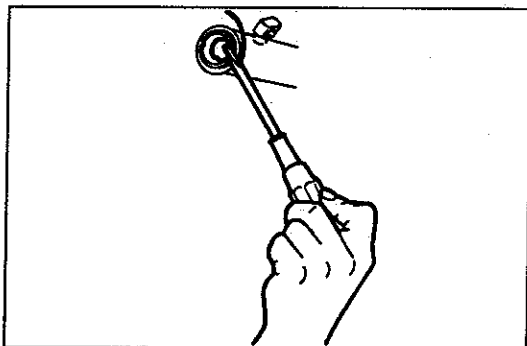
**4. Rack stop and clip**

- (1) Turn the rack stop into the housing until the holes of the stop and rack housing are aligned.
- (2) Install the new clip.
- (3) Turn the rack stop until the clip is fully installed (approx. 1.5 turns).

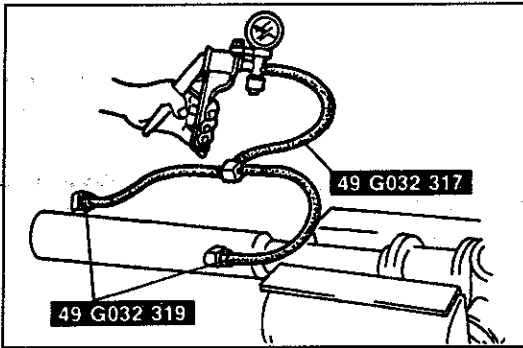

5. Hermetic inspection of cylinder

- (1) Connect the SST (adapters) to the cylinder housing.
- (2) Connect a vacuum pump to the SST (hose) and apply **53.3 KPa {400 mmHg}** vacuum.
- (3) Verify that vacuum is held for at least **30 seconds**. If not, replace the oil seals.

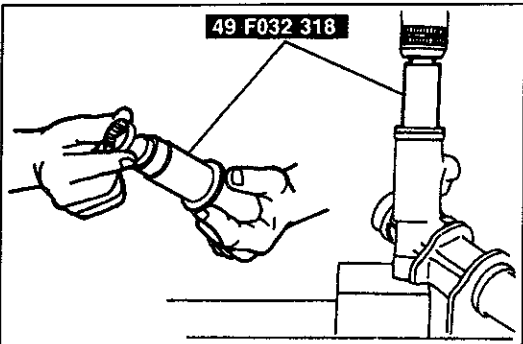

6. Needle bearing

- (1) Press in the needle bearing by using the SST.
- (2) Apply grease to the needle bearing.

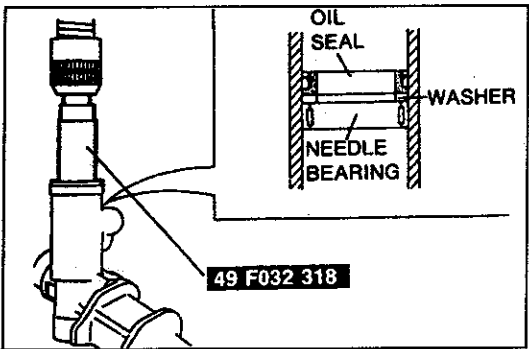

7. Washer and oil seal

- (1) Install the washer
- (2) Apply ATF to the new oil seal.
- (3) Press in the oil seal by using the SST.

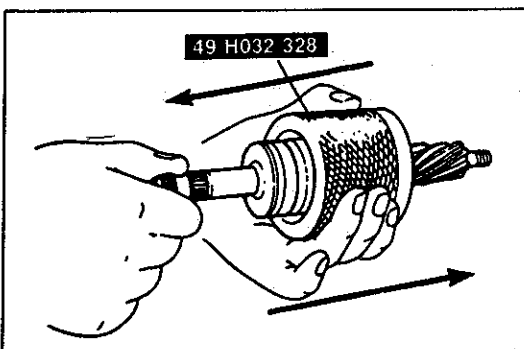

8. Seal ring

- (1) Apply ATF to the new seal rings.
- (2) Install the seal rings onto the pinion shaft assembly.
- (3) Pass the pinion shaft assembly back and forth through the SST to form the seal rings.

9. Upper bearing

- Press the upper bearing onto the pinion shaft assembly.

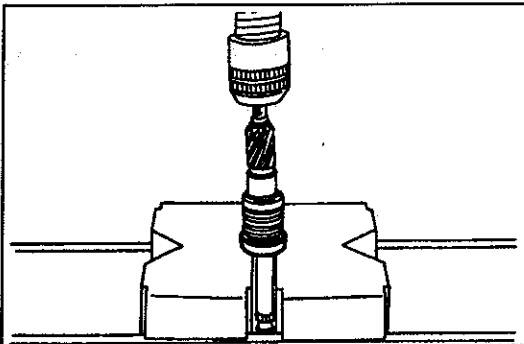

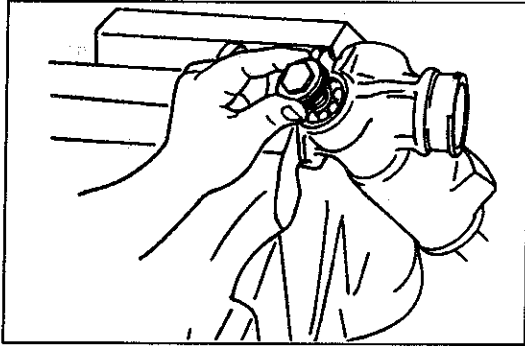

10. Pinion shaft assembly and lower bearing

- (1) Apply grease to the teeth of the rack.
- (2) Insert the pinion shaft assembly into the gear housing.
- (3) Apply grease to the lower bearing and install it onto the pinion shaft.
- (4) Seat the bearing by installing the housing cover and gradually tightening it until the tightening force suddenly increases.

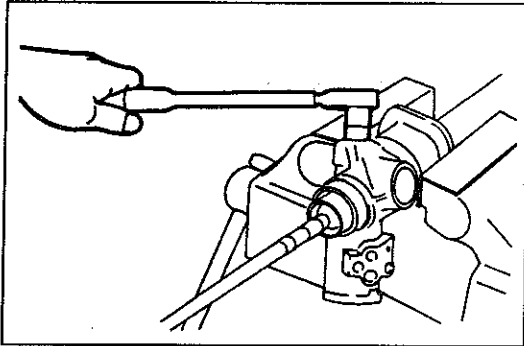

- (5) Remove the housing cover.

11. Locknut (pinion shaft)

- (1) Temporarily install the tie rod to hold the rack.
- (2) Tighten the pinion shaft locknut.

Tightening torque:

29-29 N·m {2.0-3.0 kgf·m, 15-21 ft·lbf}

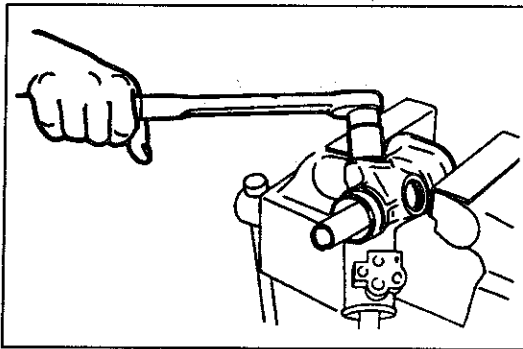

12. Housing cover

- (1) Apply a thin coat of sealant to the threads of the housing cover.
- (2) Install the housing cover.

Tightening torque:

59-69 N·m {5.9-7.0 kgf·m, 36-50 ft·lbf}

- (3) Stake the housing cover at two points by using a center punch.

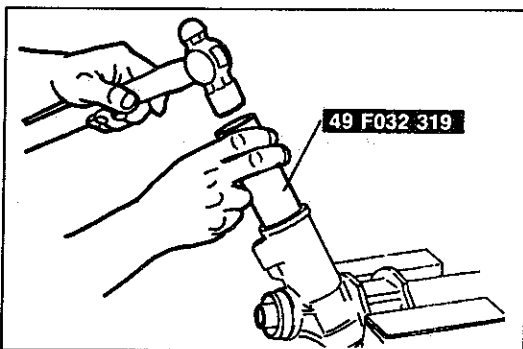

13. Oil seal (upper pinion shaft)

- (1) Install the new oil seal by using the SST.
- (2) Install the new snap ring.
- (3) Install the dust cover.

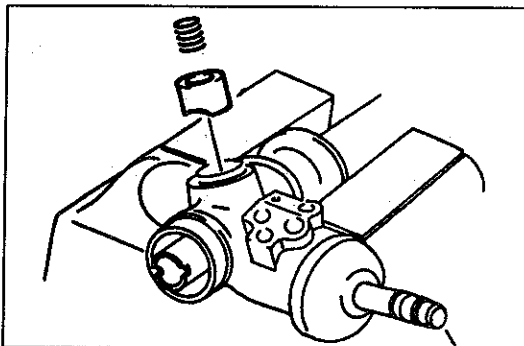

14. Support yoke assembly

- (1) Apply grease to the friction surface of the support yoke.
- (2) Install the support yoke and the yoke spring.

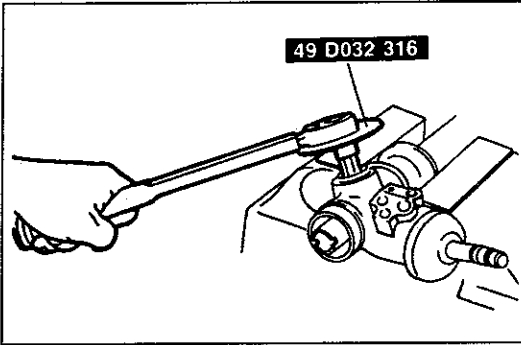

15. Adjusting cover and locknut

- (1) Apply sealant to the threads of the adjusting cover.
- (2) Using the SST as shown in the figure, tighten the adjusting cover to **9.81 N·m{100 kgf·cm,86.8 in·lbf}** and return the adjusting cover **20°–25°**.
- (3) Modify the locknut tightening torque to allow for use of a to wrench-SST combination. (Refer to section GI "Torque Formulas".)
- (4) Using the SST as shown in the figure, hold the adjusting cover in a fixed position and tighten the locknut.
(L = torque wrench length)

N·m	$N \cdot m \times L \div (L + 0.06)$
kgf·m	$kgf \cdot m \times L \div (L + 0.06)$
ft·lbf	$ft \cdot lbf \times L \div (L + 0.02)$

Tightening torque:

50–68 N·m{5.0–7.0 kgf·m,37–50 ft·lbf}

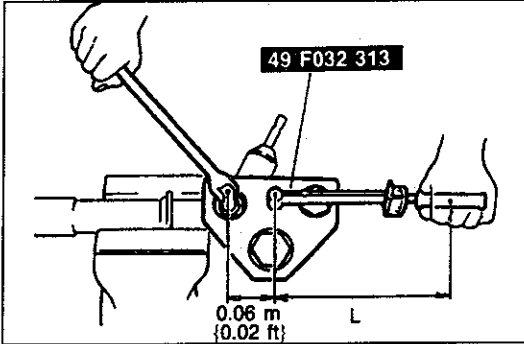

16. Measurement of pinion preload

- (1) Attach the SST and a pull scale to the pinion shaft.
- (2) Measure the pinion preload. (Center of rack ± 90 degrees)

Pinion preload: 1.5 N·m{15 kgf·cm,13 in·lbf}max.
Pull scale reading: 14.7 N·m{15 kg, 3.3 lbf}max.

- (3) If not within specification, repeat Steps 15 (2) and 15 (3).

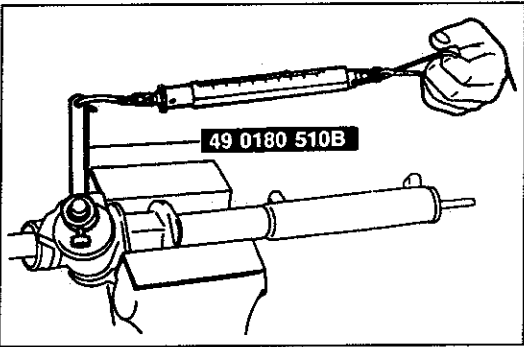

17. Tie rod

- (1) Install the tie rod by using SST.

Tightening torque:

78–98 N·m{8.0–10.0 kgf·m,58–72 ft·lbf}

- (2) Bend the new washer at two places to hold the tie rod.

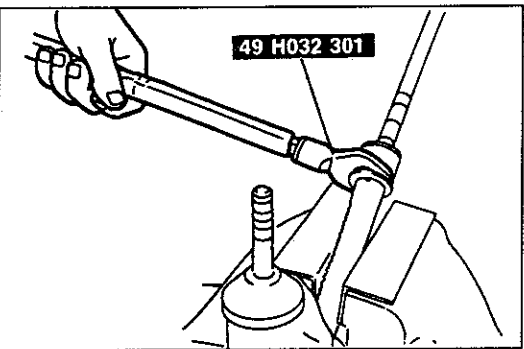

18. Boot

- (1) Apply grease to the inner bore of the small end of the boot.
- (2) Install the boot. Wrap a new boot wire around the large end of the boot two times and then twist it 4–4.5 times. Bend the twisted part toward mounting bracket.
- (3) Install a new boot clamp on the small end of the boot.
- (4) Slide the rack its full stroke and verify that the boot is not twisted.

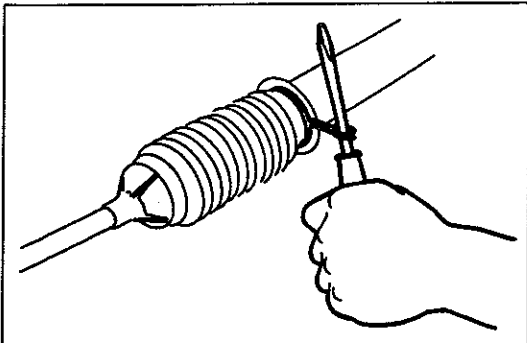

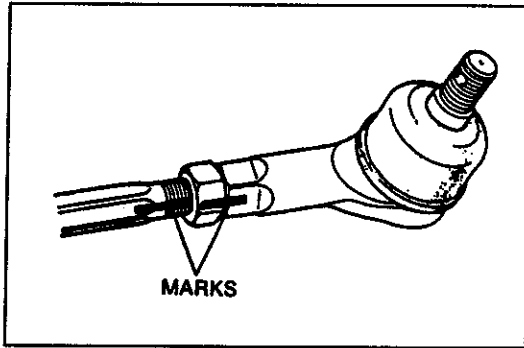

19. Tie rod end

Install the tie rod end and align the reference marks.

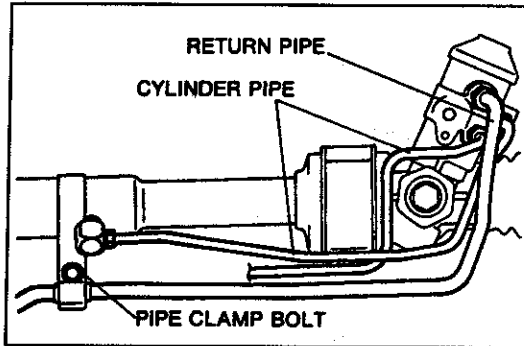

20. Oil pipe and O-ring

(1) Install the new O-rings and the oil pipes.

(2) Install the pipe clamp.

Tightening torque

Return pipe: 24–29 N·m

{2.4–3.0 kgf·m, 17–22 ft·lbf}

Cylinder pipe: 9.81–15.6 N·m

{100–160 kgf·cm, 86.9–138 in·lbf}

Pipe clamp bolt: 5.0–6.8 N·m

{50–70 kgf·cm, 44–60 in·lbf}

21. Mounting rubber and bracket

Install the mounting rubber and bracket

POWER STEERING OIL PUMP

Removal / Installation

1. Remove in the order shown in the figure, referring to **Removal Note**.
2. Inspect all parts and repair or replace as necessary.
3. Install in the reverse order of removal, referring to **Installation Note**.
4. After installation:
 - (1) Adjust the belt deflection. (Refer to page N-31.)
 - (2) Check connections for fluid leakage. (Refer to page N-7.)
 - (3) Bleed air from the system. (Refer to page N-6.)

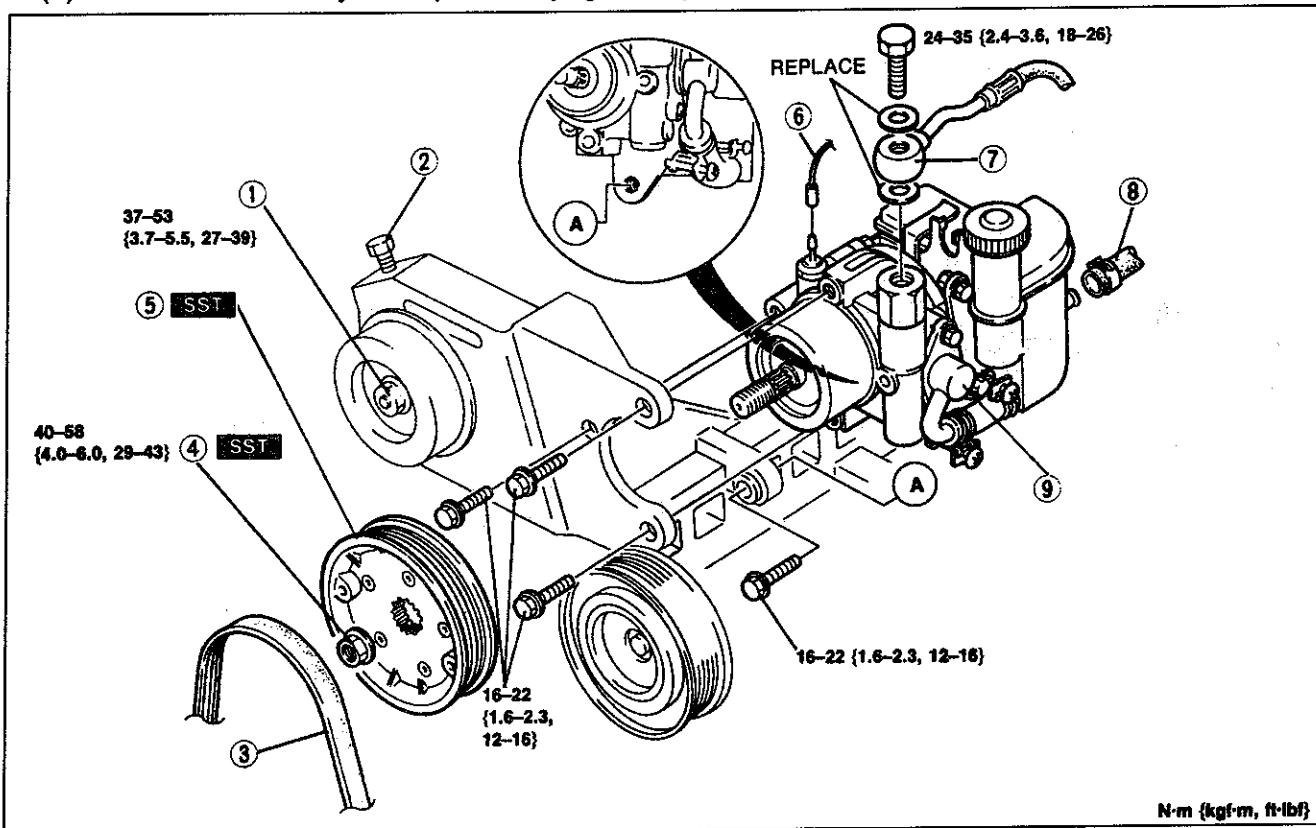

- | | |
|---|---|
| <ol style="list-style-type: none"> 1. Locknut 2. Adjusting bolt 3. Drive belt 4. Nut 5. Pulley | <ol style="list-style-type: none"> 6. Steering pressure sensor connector 7. Pressure hose 8. Return hose 9. Power steering oil pump |
|---|---|
- Removal / Installation Note below
- Disassembly / Inspection / Assembly page N-29

Removal / Installation note

Nut / Pulley

Hold the pulley by using the SST and loosen / tighten the nut.

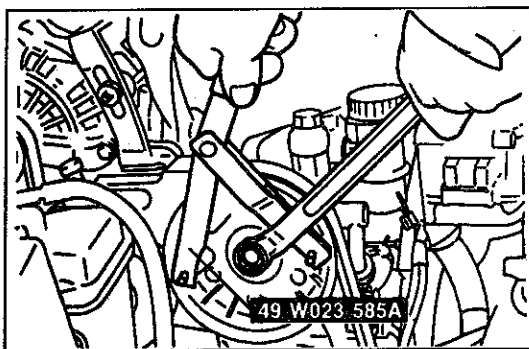

Disassembly / Inspection / Assembly

1. The following procedure is for replacement of the O-rings only. Replace the oil pump assembly if other repairs are necessary.
2. Disassemble in the order shown in the figure, referring to **Disassembly Note**.
3. Assemble in the reverse order of disassembly, referring to **Assembly Note**.

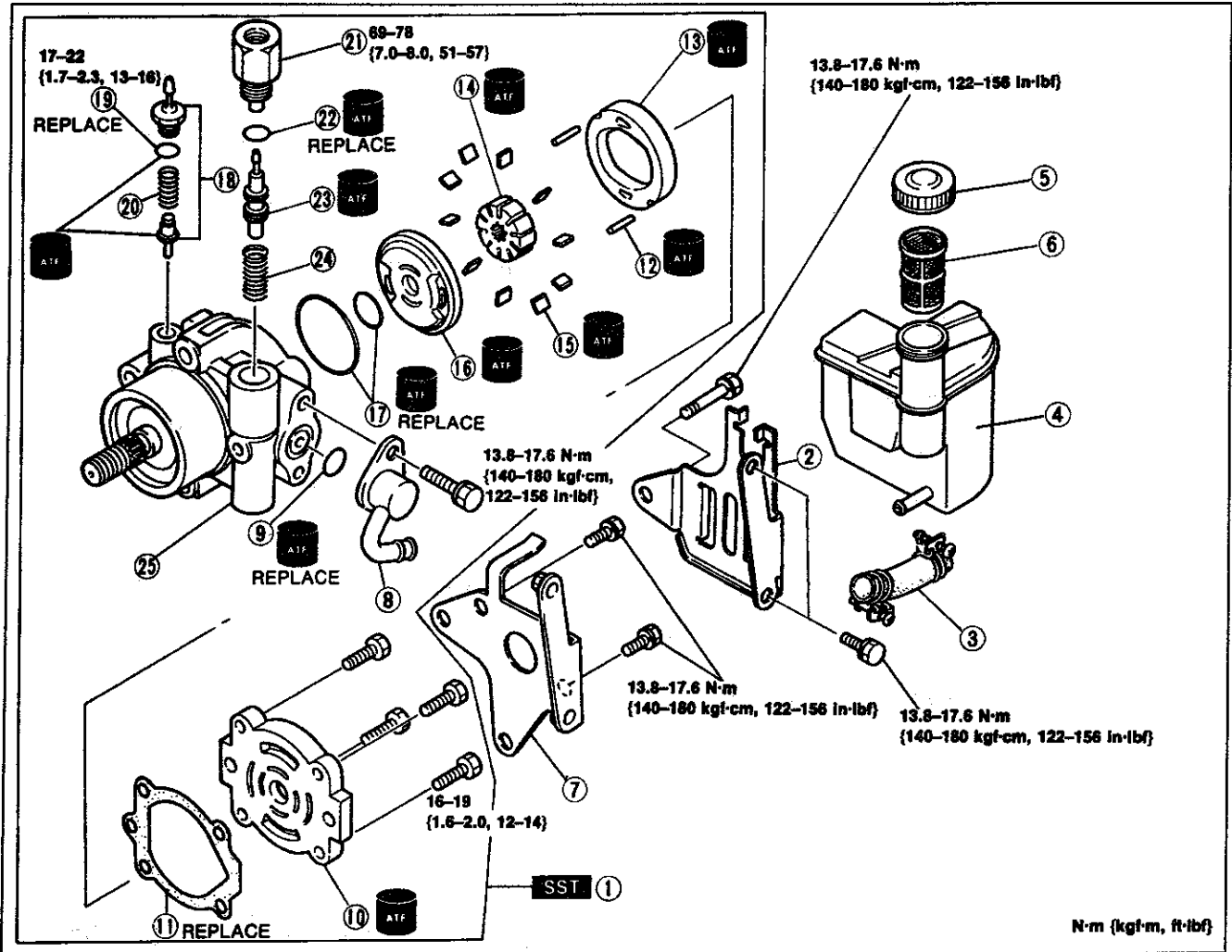

- | | |
|---|--|
| <ol style="list-style-type: none"> 1. Oil pump
Disassembly Note page N-30 2. Bracket 3. Suction hose
Inspect for cracks and damage 4. Reservoir
Inspect for cracks and damage 5. Cap 6. Filter
Inspect for clogging 7. Bracket 8. Suction pipe 9. O-ring 10. Pump body (rear)
Assembly Note page N-30
Inspect for cracks, wear, and damage 11. Gasket 12. Pin 13. Cam ring
Assembly Note page N-30
Inspect for wear and damage | <ol style="list-style-type: none"> 14. Rotor
Inspect for wear and damage 15. Blade
Assembly Note page N-30
Inspect for wear and damage 16. Side plate
Inspect for wear and damage 17. O-ring 18. Steering pressure sensor assembly 19. O-ring 20. Spring
Inspect for weakness 21. Connector 22. O-ring 23. Control valve
Inspect for clogging, cracks, and damage 24. Spring
Inspect for weakness 25. Pump body (front)
Inspect for cracks, wear, and damage |
|---|--|

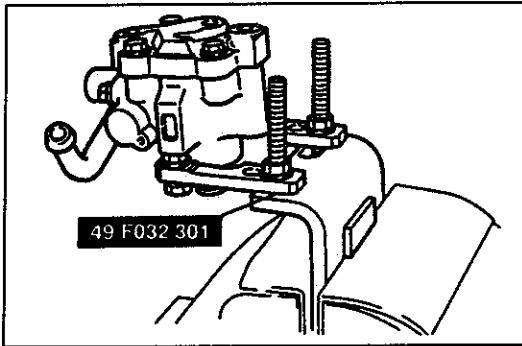
**Disassembly note****Oil pump**

Install the pump to the SST, and hold the pump and SST in a vise.

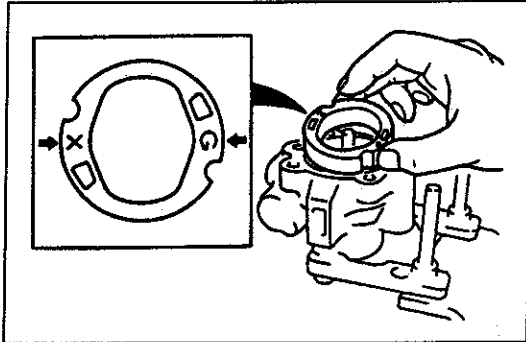
**Assembly note****Cam ring**

Install the cam ring in the front pump body with the marks facing upward.

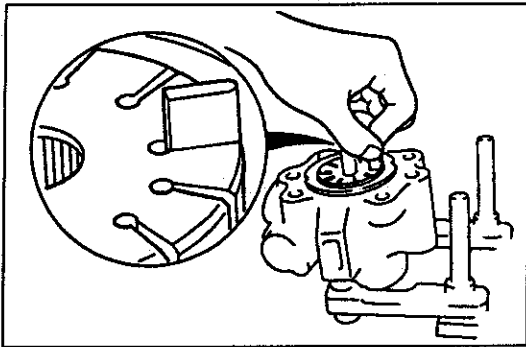
**Blade**

Place the blades in the rotor so that the rounded edges contact the cam.

Pump body (rear)

After installing the rear pump body, manually turn the shaft to verify that it rotates smoothly.

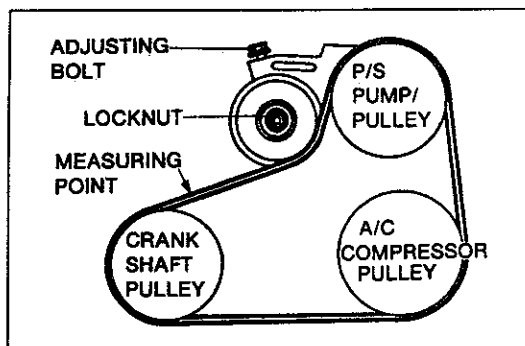

DRIVE BELT

Inspection

1. Check the drive belt for wear, cracks, and fraying. Replace if necessary.
2. Verify that the drive belt is correctly mounted on the pulleys.
3. Check the drive belt deflection when the engine is cold, or at least 30 minutes after the engine has stopped. Apply moderate pressure (98 N {10 kgf, 22 lbf}) midway between the specified pulleys.

Deflection

mm{in}		
New	Used	Limit
3.5-4 {0.14-0.15}*	4.5-5 {0.18-0.19}	6 {0.23}

* A belt that has been on a running engine for less than 5 minutes

4. If the deflection is not within specification, adjust it.

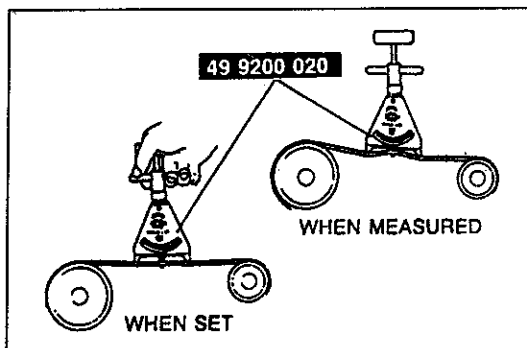

Drive belt tension check

Belt tension can be checked in place of belt deflection. Check the drive belt tension when the engine is cold, or at least 30 minutes after the engine has stopped. Using the SST, check the belt tension between any two pulleys.

Tension

N {kgf, lbf}		
New	Used	Limit
740-880 {75-90, 165-198}	540-630 {55-65, 121-143}	320 {33, 73}

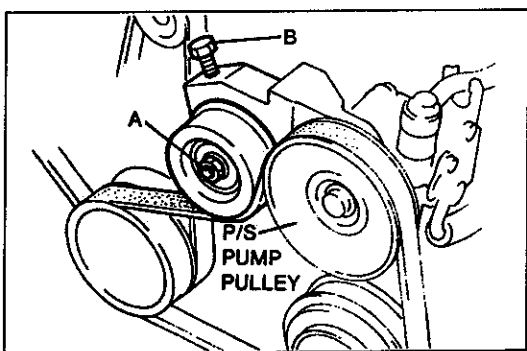

Adjustment

1. Loosen idler pulley locknut A, and adjust the belt deflection or tension by turning adjusting bolt B.
2. Tighten locknut A.

Tightening torque

A: 37-53 N·m {3.7-5.5 kgf·m, 27-39 ft·lbf}

Replacement

1. Loosen locknut A and adjusting bolt B.
2. Remove and replace the drive belt.
3. Adjust the deflection or tension.(Refer to above.)